

## Jamboree exhibition setup: food and furniture

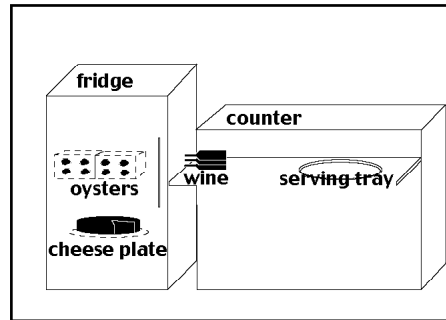

These pages present a design overview of what we plan to demonstrate in the Jamboree demonstration.

There will be a series of Smart-Its tagged physical props (furniture and food/food-shaped objects) and a related video projection. Jamboree visitors can interact with the props to get readings and scenarios generated on the video projection. The projection will display percepts values and simulations of application interfaces located in the restaurant (for example, a video animation of prices changing on a menu as a Jamboree visitor shakes the wine bottle).

## Smart-Its locations

- gateway Smart-Its
- Smart-Its

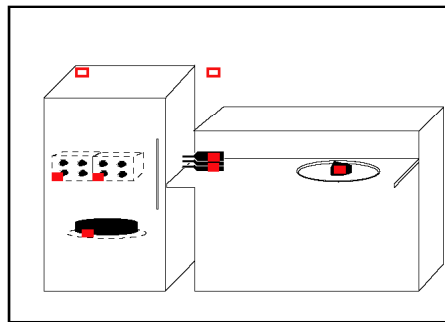

The scenarios outlined here are:

- "updating the status of items in fridge"
- "monitoring quality (decay) of items"
- "cheese and wine ready to be served"
- "running out of cheese"

These are meant to contextualize the other technical documentation and give a bigger picture of how the individual percepts fit together in the planned Jamboree demo.

## "updating status of items in fridge"

storage state

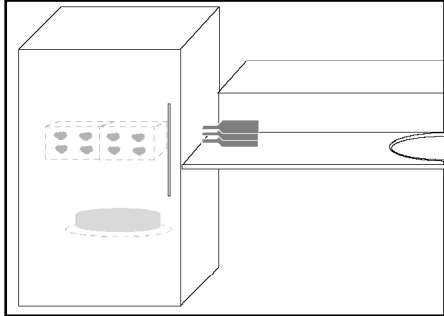

fridge door is opened to check contents

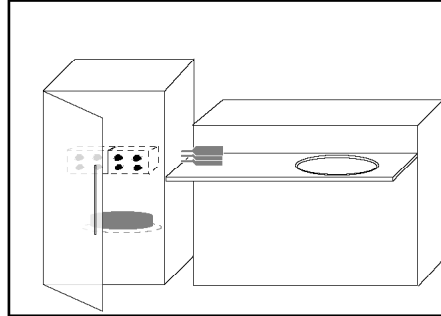

status of fridge items is updated

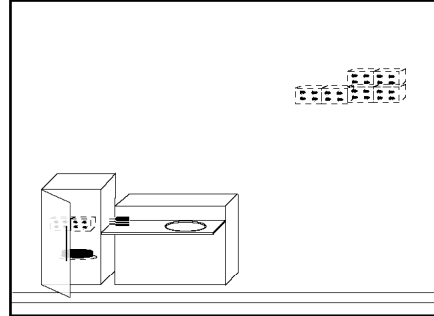

**CONCEPT:** Opening the fridge door opens a channel of communication between items within the fridge and items outside of the fridge.

**DEMO:** Here, oysters inside the fridge are triggered to check their status in relation to other oysters outside the fridge (at the docks or in a truck), and also to update their status for relevant applications or items external to the fridge.

**PERCEPTION:** this will probably be simulated in the Demo, using a switch on the fridge door or by sensing communication between the gateway Smart-It in the fridge and the one outside.

## "monitoring quality (decay) of items"

storage state

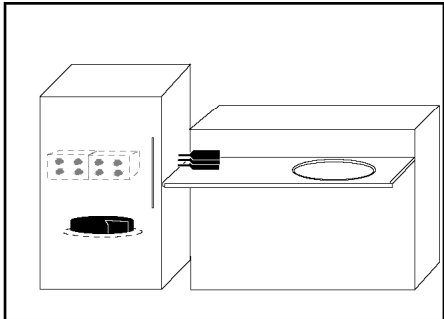

differing treatment of wine bottles

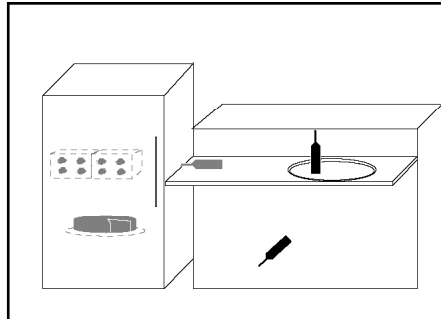

quality of fresh items gets worse

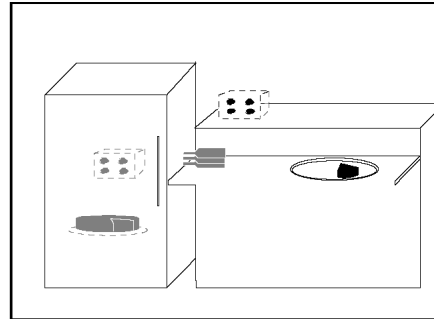

**CONCEPT:** Items can be queried as to their status, as well as signal when significant changes affect their quality.

**DEMO:** Each food item will keep track of its treatment (temperature, whether it has been shaken up, light exposure). This information will be collected, associated with the item identity, and make up a reading as to the overall quality of the item along a 'decay curve' for each type of item (ie., wine, oysters and cheese have different optimal temperatures, age, times to go bad).

**PERCEPTION:** sensor values are collected and associated with appropriate treatment and in relation to some sort of 'decay curve'

## "cheese and wine course ready to be served"

storage state

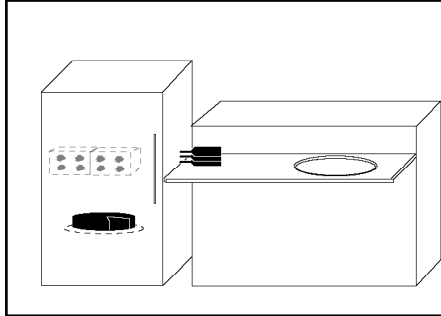

items removed and put on tray

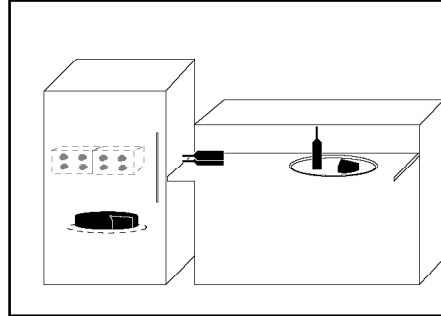

'chef puts complete order out to be served

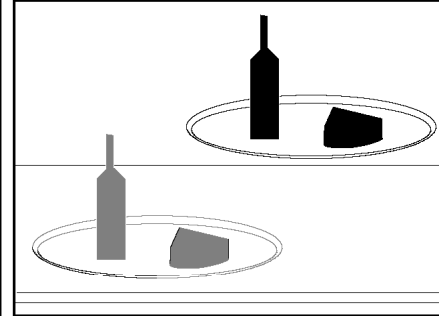

order is ready to be served

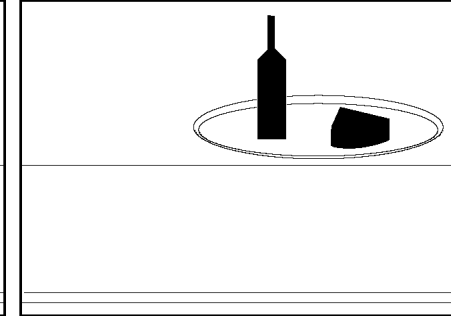

**CONCEPT:** A combination of user involvement (chef) and perception enable an order to know when it is ready to be served.

**DEMO:** Once all the right items have been put on the tray (3 Smart-Its tagged items), the chef moves the tray to another counter. The action of moving the items together groups them and signals that the order is complete. Once the order is complete and all items are at the proper serving temperature, the tray will signal that it is ready to be delivered to the table.

## "running out of cheese"

items removed and put on tray

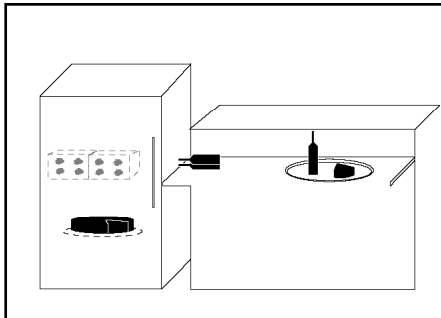

cheese plate knows there is less cheese

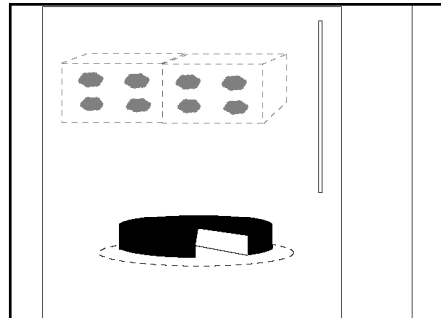

**CONCEPT:** Certain containers are aware and monitoring their contents. This could be monitoring in the sense of quality (such as the fridge checking on the oysters) or in terms of amounts.

**IMPLEMENTATION:** In this demo, a cheese plate is monitoring the amount of cheese it contains, and will send an alert if the contents are running low.

**PERCEPTION:** pressure sensor monitors weight in relation to starting weight.

**PERCEPTION:** smart-its items will be oriented all in the same direction - perception of directional acceleration, light, noise (these as necessary) combine to determine that the items are a group.